

BuildIT Construction Software

Complete Solution for Continuous Construction Verification

Construction Software Platform for AEC Professionals

Construction sites are becoming remote factories in need of build and verify solutions. Historically, the tolerance level for scrap and rework has been very high because it is considered a part of the normal business - until now.

FARO® introduces BuildIT Construction, the first fully integrated building lifecycle Quality Assurance (QA) and Quality Control (QC) management tool empowering construction professionals to continuously evaluate projects with real time comparisons against CAD designs using 3D scan data.



Accelerate the Project Schedule and Minimise the Waste

Validate to Design

Guarantee that buildings and structures are being constructed to design specifications

- Verify accuracy of scan data to design models
- Detect incorrect placement or missing features such as walls, columns, beams, pipes, etc....

Tolerance Evaluation

Preserve and accelerate the project schedule while reducing scrap, time and resources

- Perform important measurements accurately and quickly
- Inspect construction for adherence to building standards (Floor Flatness/Floor Levelness, Beam Camber, Cut & Fill Volume, Wall Plumbness, Tank Deformation and Volume Analysis)

Position and Monitor

Establish liability documentation, risk mitigation and quality prefabrication

- Verify shifts and movements within structural performance over time with 4D analysis
- Perform real time monitoring of adjacent structures throughout the project lifecycle

Benefits

BuildIT Construction leverages FARO's cutting-edge 3D metrology capability derived from 20 years of proven expertise in delivering best in class measurement solutions to the manufacturing industry. BuildIT Construction by FARO is a comprehensive verification software solution that enables confident management of all quality assurance and quality control processes throughout the building and facility lifecycle.

Accelerate the Project: Utilising complete digital 3D scans, quickly and easily perform construction QA/QC analysis, reducing prolonged hours of manual validation to mere minutes.

Minimise the Waste: Perform routine quality checks throughout the build process to detect errors at every stage of the project lifecycle and reduce expensive scrap and rework.

Measure with Confidence: Conduct your analysis using an established platform derived from 20 years of proven expertise in delivering best in class measurement solutions to the manufacturing industry.

Accelerate Daily Work: Avoid manual, time consuming repetition of individual steps with automated processes from importing of 3D data to reporting on various tasks and projects.

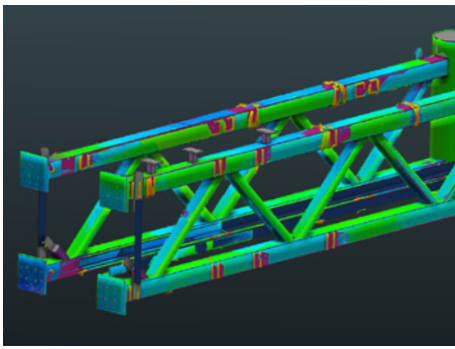

Surface analysis

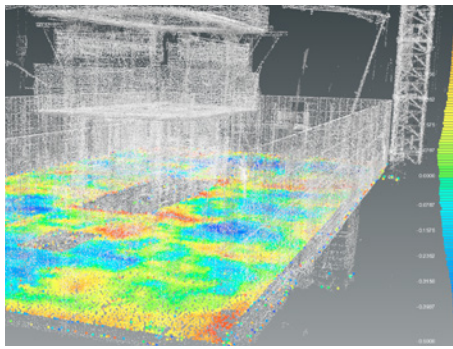

Floor Flatness & Floor Levelness (FF/FL)

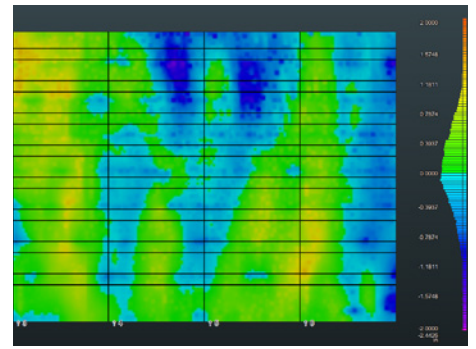

Tank Analysis

Capabilities

Validation to Design Data

- Verify accuracy of as-built scan data to design models
- Perform surface analysis against any modeled object
- Ensure adherence to BIM
 - Identify components or assemblies that were constructed
 - Detect incorrect placement or missing features such as walls, columns, beams, pipes, etc...

Tolerance Evaluation

- Perform important inspections accurately and quickly
 - Inspect floor flatness and levelness to the ASTM E1155 standard, with accompanying report and topographic curves
 - Check walls for plumb and flatness with or without design models
 - Calculate cut and fill volumes accurately and effectively with wall detection, debris and rebar removal
 - Measure the deformation of constructed objects (ie. beam camber, wall and floor flatness, cracks, and more)
 - Calculate the fill volume for tanks from scan data and create reports automatically
 - Create detailed tank deformation reports using a suite of commands for horizontal, vertical and grid analysis.

Position and Monitor

- Conduct 4D Cloud to Cloud comparisons
 - Monitor adjacent buildings during construction
 - Evaluate site deformation to measure movement or settling over time
- Interface with laser projectors to:
 - Project design templates for prefabricated parts and assemblies
 - Project equipment placement for factory layout and planning
 - Measure flatness and project the results back onto the surface
- Position structural elements and prefabricated parts in real time using laser trackers or total stations

Data Import Utility

- Import scan data from various laser scanner manufacturers and CAD platforms from file types such as: asc, csv, e57, fls, fws, las, laz, lsproj, pts, ref, txt, xyz
- Upon import, data can be registered using SCENE's registration API. Begin quality control onsite and speed up the inspection process
- Import design files in industry-standard formats: Autodesk® AutoCAD® (dwg and dxf versions 2.5-2020), Revit (2015-2019), IFC (2x3, 4), sat, iges, Parasolid, Step

Detailed Reporting

- Customise reports to include only the relevant information
 - Add models, views, scan data and analyses by selecting them in the Object Manager or the Graphical Display
 - Generate charts, graphs, screenshots and data tables
 - Export as PDF, XLSX, CSV

Industries

Architecture | Civil/Survey | Construction | Facility Management | Historical Preservation | Mechanical, Electrical and Plumbing (MEP)

Applications

BuildIT Construction Software from FARO uniquely enables laser scanner users to perform immediate, real time build and verify analysis throughout the entire project and facilitates a new level of cost management and operational efficiency.

- Fully integrated with 3D data collected from FARO Focus Laser Scanners
- Optimised for the FARO Tracer Laser Projector for placement and layout of structural components
- Compatible with the FARO Laser Tracker for prefabricated modular positioning
- Used seamlessly with other third-party hardware

| Hardware Requirements | Minimum Requirements | Recommended Requirements |
|-----------------------|--|---|
| Operating System | Microsoft Windows 10, 64-bit | Microsoft Windows 10, 64-bit |
| Processor | Intel Core i3 or equivalent | Intel Core i7 or equivalent |
| RAM | 8 GB | 16 GB+ |
| Hard Drive | 20 GB of free solid state hard drive space | 250 GB of free solid state hard drive space |
| Graphics Card* | Integrated graphics; OpenGL 4.0 | NVIDIA Quadro series or equivalent with 2GB (VRAM); OpenGL 4.2+ and OpenCL 1.2+ |

*We recommend updating the video driver to the most recent released version from the manufacturer website

Freecall 00 800 3276 7253 | info.emea@faro.com | www.faro.com

FARO Europe GmbH & Co. KG | Lingwiesenstrasse 11/2 | 70825 Korntal-Münchingen

