



# The benefits of using AutoCAD vs. AutoCAD LT



# Introduction

AutoCAD® has seen over 30 versions in its time, with each version of the software becoming more sophisticated and new features added with every release. There are two variants of AutoCAD available: AutoCAD

and AutoCAD LT®. Both variants run the same core features. However, AutoCAD offers both 2D and 3D drafting and automation capabilities while AutoCAD LT offers a comprehensive 2D drafting toolset.

## Executive summary

Designed by Autodesk and commissioned to an outside consultant, this study explored some of the major differences between AutoCAD and AutoCAD LT and related productivity and commercial differentiations. This included functional comparisons and some core differences between the two applications. For example, compared to AutoCAD, a 2D isometric view can be created in AutoCAD LT using the same constraints as a 3D isometric view, but it cannot be manipulated as easily, since 3D solids can't be created in AutoCAD LT.

Throughout this study, a set of design documents were created by using both AutoCAD and AutoCAD LT, with tasks ranging from creating geometry to creating plans and elevations, extracting object data, and applying and monitoring CAD standards.

The study showed that AutoCAD could achieve a level of productivity for design creation that is not matched with AutoCAD LT. And, overall, AutoCAD could allow an AutoCAD designer to generate designs up to **7.1 times quicker** as compared to AutoCAD LT.

As shown in this study, a user could achieve **time savings up to 86%** by using AutoCAD instead of AutoCAD LT to complete the series of tasks detailed below. However, should there be a requirement simply for 2D drafting, some of the gains achieved with AutoCAD would be reduced.

All of the above would depend on the user's expertise level both with AutoCAD and AutoCAD LT.

# Key time savings



## Faster

The editing and managing of parametric constraints was about **33%** faster using AutoCAD.

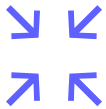

## Reduced

AutoCAD reduced the time taken to create and edit plans and elevations by about **46%**.



## Saved

Using CAD standards in AutoCAD could provide timesavings of up to **81%**.



## Gained

There was an overall time savings of up to **86%** when using AutoCAD.

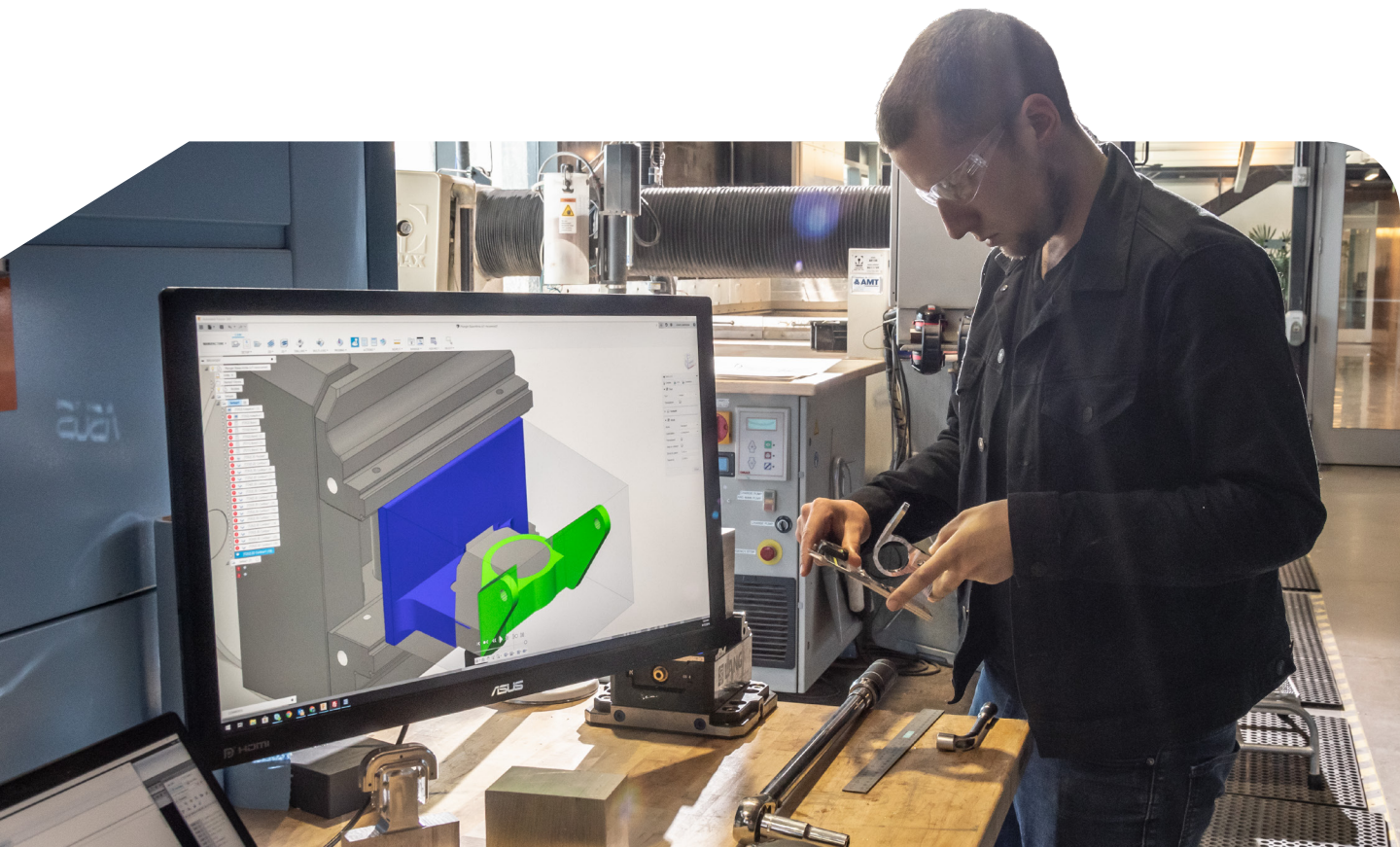

# The study

This study explored and compared AutoCAD LT and AutoCAD. Using common design challenges, the study showed the direct comparisons of time and effort required to accomplish specific tasks in AutoCAD LT versus AutoCAD\*.

## The tasks performed in the study were completed up to **86%** faster using AutoCAD.\*

The performance results in this paper were achieved by one user, with expert-level experience, using both AutoCAD LT and AutoCAD, conducting comparative tests using various AutoCAD filetypes, such as DWG and DWS. The tasks are comprehensive in nature. The total time it took to complete each task using both AutoCAD LT and AutoCAD are documented in each case.

It was assumed during the study that all symbols and title blocks needed in AutoCAD LT and AutoCAD for the design process were local to the document. Searching time varies and the methodologies allowed for the quick placement of required blocks in the shortest amount of time possible.

A detailed description of the study follows.

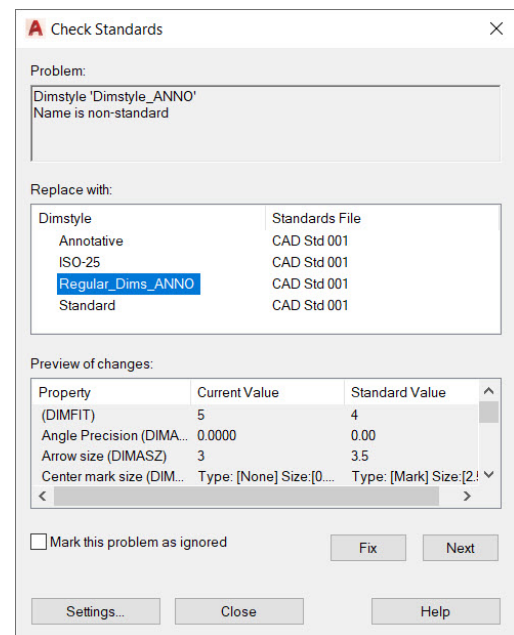
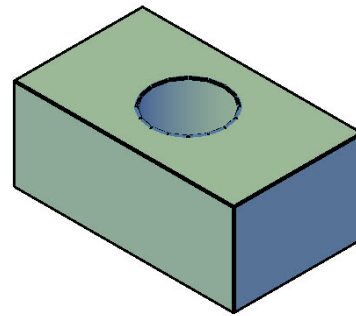
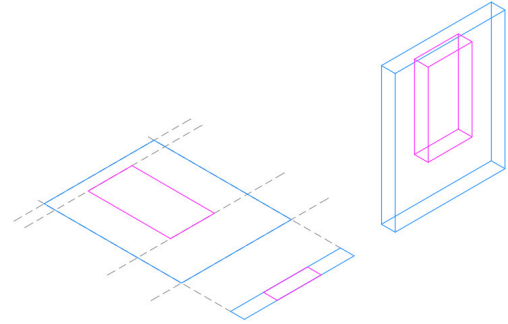

## Design task 1

# Parametric constraints

The task was to work on a collaborative design drawing of a simple bracket with geometric and dimensional constraints, and then edit the constraints for a design specification. The constraints of the bracket include a need to maintain geometric consistency for design feasibility and accurate dimensional constraints for ease of manufacturing.

## Steps

1. Assess geometric constraints using the Show/Hide function
2. Assess dimensional constraints using the Show/Hide function
3. Edit and delete constraints, where applicable, to allow the design to meet changes in specification

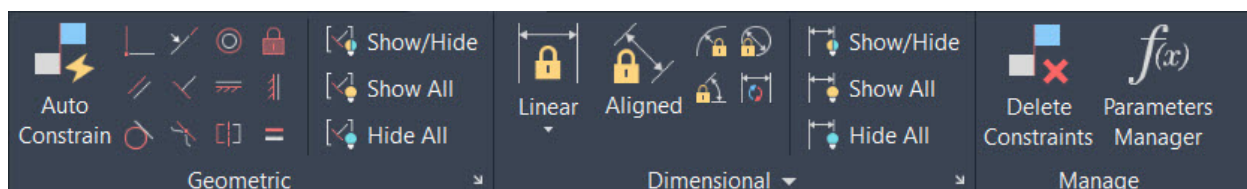
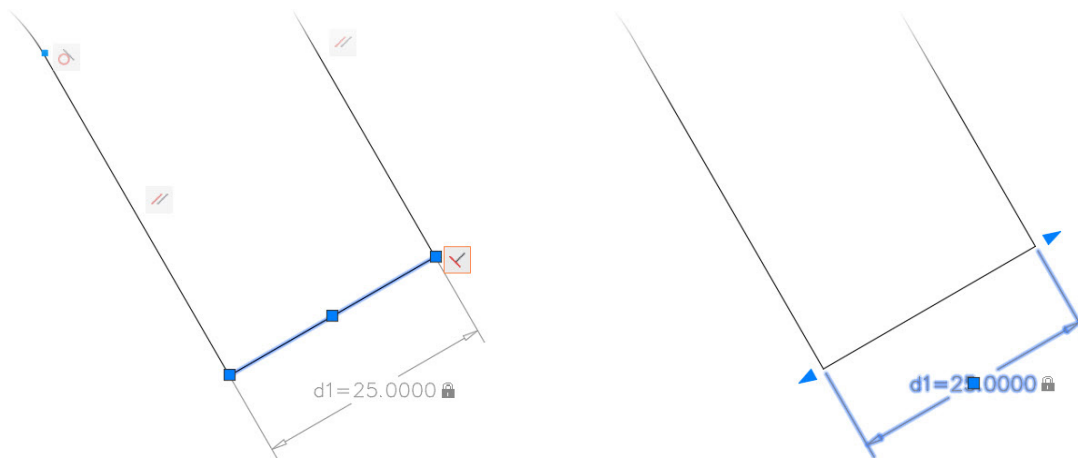

Parametric Constraints	AutoCAD LT	AutoCAD
Assess geometric constraints	2:30	2:30
Assess dimensional constraints	2:30	2:30
Edit/delete parametric constraints	5:30	2:00
Total time to complete task	10:30	7:00
<b>Time Savings with AutoCAD</b>		<b>33%</b>

(Figures shown in minutes and seconds)

## Advantages

- AutoCAD offers complete geometric and dimensional constraint creation, editing, and management of parametric constraints, while AutoCAD LT only allows the display of any constraints and any corresponding parameter editing and deletion
- There is a Parametric tab in the AutoCAD LT ribbon, allowing access to the Parameters Manager, but this tends to be for editing only. You cannot create parameters in AutoCAD LT, but you can delete them, which can lead to constraints being removed from a design and not being available when the drawing is opened again in AutoCAD.



## Design task 2

# Plans and elevations

The task was to generate a simple wall, both in plan and elevation in a drawing to show the positioning of the window opening. The plan needed to show the horizontal location of the window in the wall and the wall thickness. The elevation needed to display the wall's length and height and the height of the window opening in the wall.

### Steps:

1. Create a plan view of the wall
2. Create an elevation view of the wall
3. Display the window position in the plan view
4. Display the window position in the elevation view

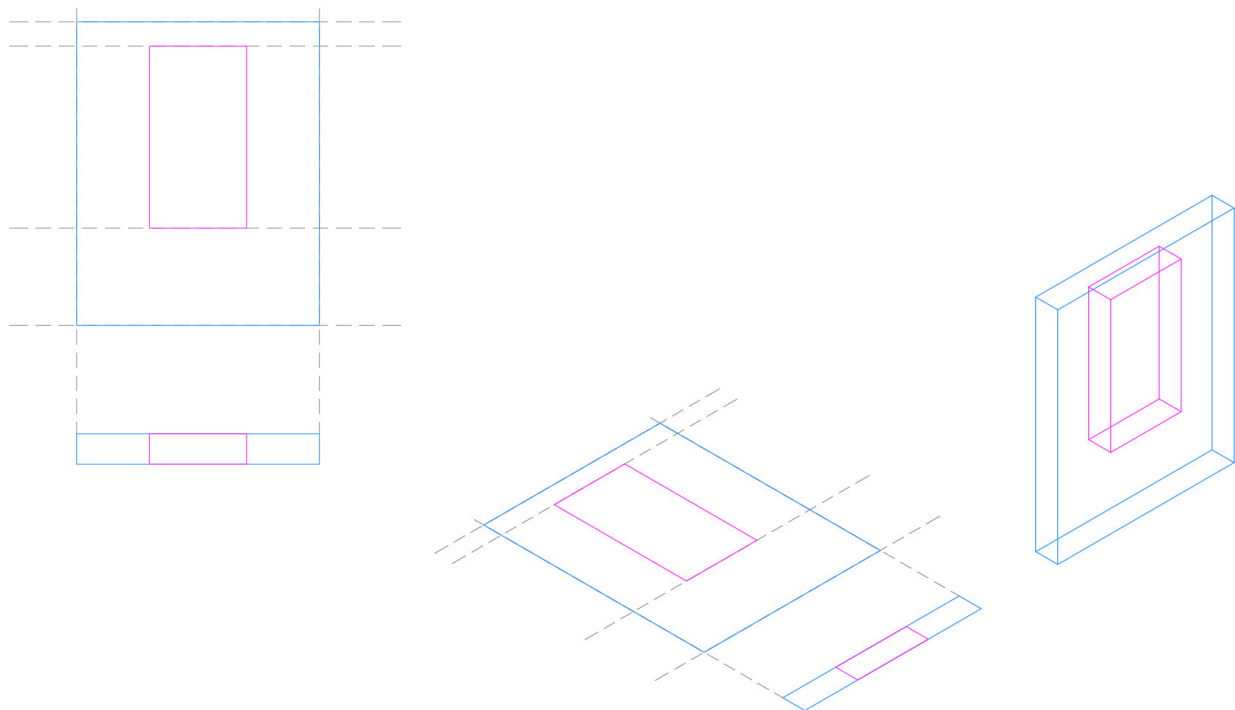

Plans and elevations	AutoCAD LT	AutoCAD
Create a plan view of a wall	1:00	1:00
Create an elevation view of the wall	2:00	0:30
Display the window position in the plan view	1:00	1:00
Display the window position in the elevation view	2:30	1:00
Total time to complete task	6:30	3:30
<b>Time Savings with AutoCAD</b>		<b>46%</b>

(Figures shown in minutes and seconds)

## Advantages

AutoCAD provides the following advantages:

- 2D drafting tools allow for fast 2D plan creation
- 3D modeling tools can be used for easy manipulation of the 2D plan objects
- Specific views of the 3D solids can then be used in the elevation view.





## Design task 3

# Isometric drafting

A 3D isometric view of an object created a view where the angle between the projections of the X, Y, and Z axes are all the same (120 degrees). A 2D isometric view may also be created using the same constraints, but it cannot be manipulated as easily as the 3D isometric view because 3D solids can't be created in AutoCAD LT.

The task was to generate an isometric view in a basic drawing using the X, Y, and Z axes in their isometric positions. The object shown in the drawing is a rectangular base with a circular hole through the center.

### Steps:

- Generate the rectangular base in an isometric view
- Add the circle object to generate the hole at the center
- Edit any objects to hide any hidden object lines

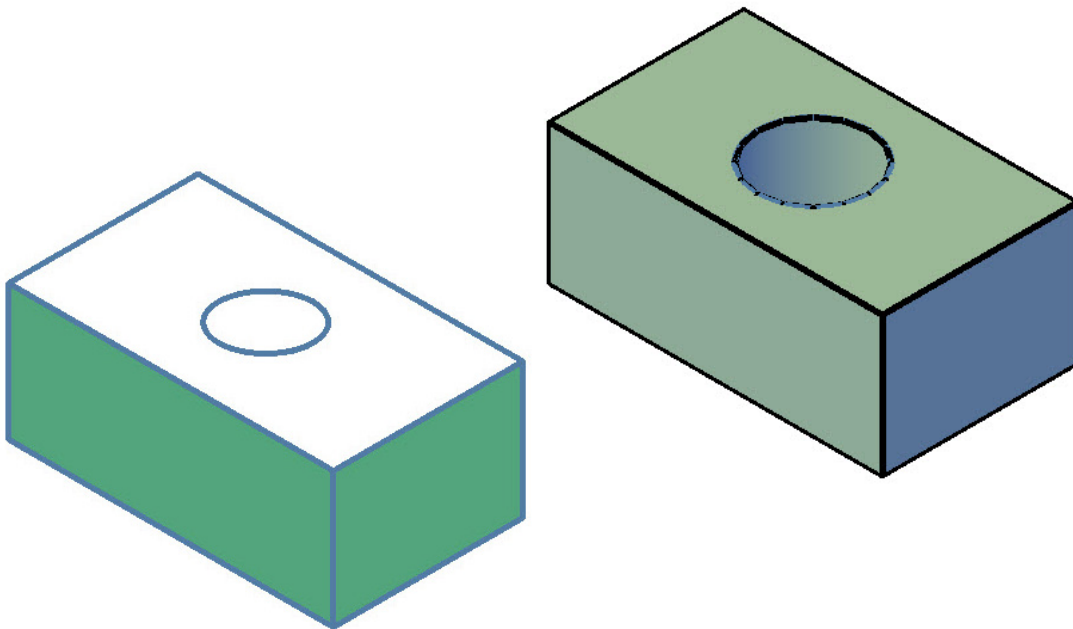

<b>Isometric drafting</b>	<b>AutoCAD LT</b>	<b>AutoCAD</b>
Generate rectangular base object	5:00	2:30
Place circle object and create center hole	7:30	2:30
Edit any objects to hide any hidden details	1:30	0:30
Total time to complete task	14:00	5:30
<b>Time Savings with AutoCAD</b>		<b>61%</b>

(Figures shown in minutes and seconds)

## Advantages

AutoCAD offers generous time savings here because:

- 3D isometric representations in AutoCAD LT must use 2D modeling
- AutoCAD has visual styles that can be set to hide hidden detail
- AutoCAD can view 3D objects in isometric views

## Design task 4

# Data extraction

The task, in this case, was to calculate the block and attribute count in a drawing. This involves the counting of three attributes: Desk Number (DESKNO), Employee Name (EMPNAME), and Employee Number (EMPNO). These attributes are associated with an AutoCAD block reference (WORKSTATION) that is made up of three nested blocks: Executive Chair, Executive Desk, and Filing Cabinet.

### Steps:

- Count the instances of the three block attributes associated with the WORKSTATION block
- List the specific information in each of the above-named block attributes
- Count the instances of the nested blocks in the WORKSTATION block
- Put all block and attribute data into an AutoCAD table and insert the table into the drawing

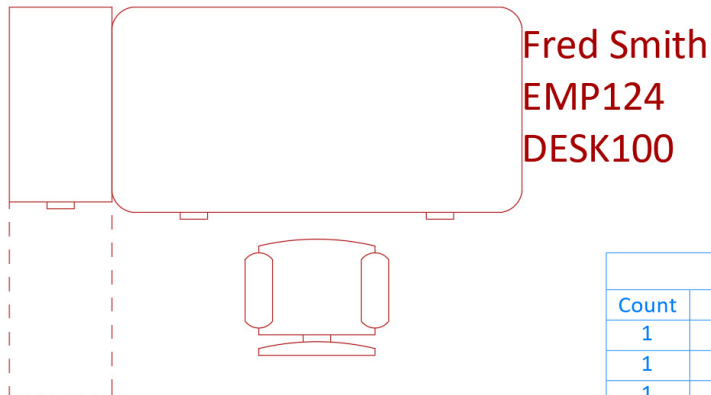

Workstations - DATA				
Count	Name	DESKNO	EMPNAME	EMPNO
1	Workstation	DESK102	Valerie Hedges	EMP126
1	Workstation	DESK103	Michael Jones	EMP127
1	Workstation	DESK104	Edwina Biriyani	EMP128
1	Workstation	DESK099	Bert Bloggs	EMP123
1	Workstation	DESK100	Fred Smith	EMP124
1	Workstation	DESK101	Tony Eckhart	EMP125
6	Filing Cabinet			
6	Executive Chair			
6	Executive Desk			

Data extraction	AutoCAD LT	AutoCAD
Count the instances of block attributes	60:00	5:00
List the specific block attribute information	55:00	5:00
Count the instances of nested blocks in the drawing	60:00	5:00
Put all block and attribute data into an AutoCAD table	50:00	1:00
Total time to complete task	225:00	16:00
<b>Time Savings with AutoCAD</b>		<b>93%</b>

(Figures shown in minutes and seconds)

## Advantages

When extracting data from a DWG file, the following was noted:

- AutoCAD offers a data extraction command (DATAEXTRACTION) that interrogates the drawing, providing block and attribute data
- Data extraction from the drawing in AutoCAD LT was done manually, with the use of Microsoft Excel to log all necessary data
- AutoCAD provides the facility to list the extracted data into an AutoCAD table in the drawing or into a Microsoft Excel file (.xls)

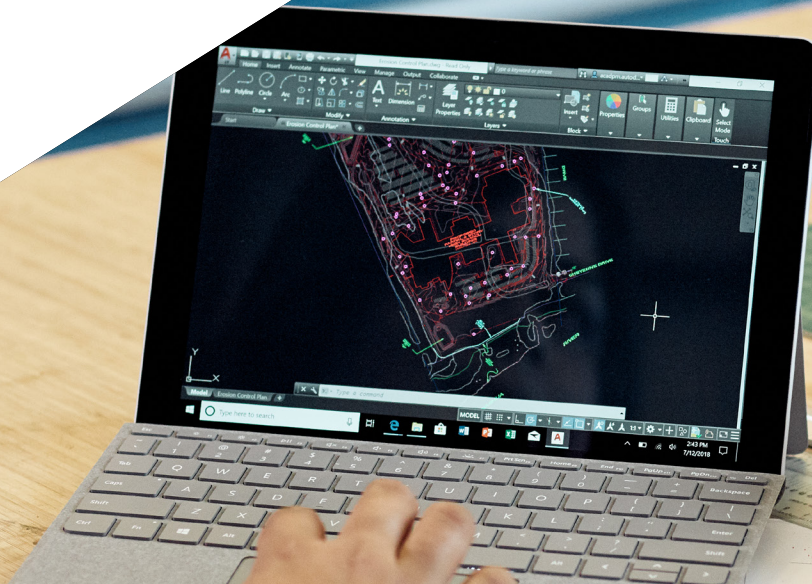

## Design task 5

# CAD standards

CAD standards are a fundamental part of any AutoCAD workflow. They are often mandatory on projects that use AutoCAD to communicate design intent. Often, when receiving drawings from third parties, you need to check certain standards to comply with in-house CAD requirements.

The task was to check the drawing elements of layers, text, and dimensions against a preset CAD standard in a drawing received from a third party.

### Steps:

- Locate the CAD standard to apply the checking procedure
- Check layers, text, and dimensions against the standard
- Adjust the third-party drawing accordingly

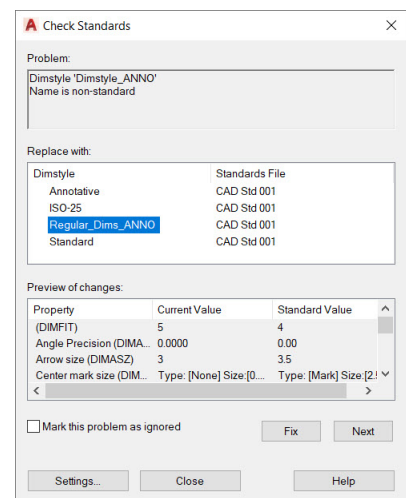
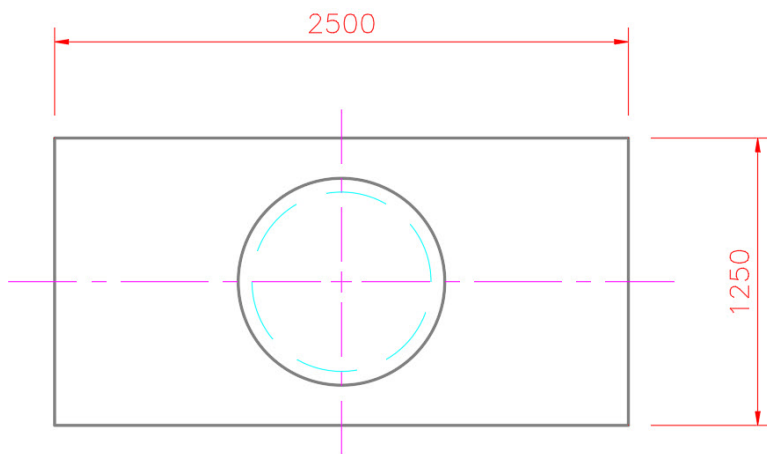

CAD standards	AutoCAD LT	AutoCAD
Locate the CAD standard to be checked against	5:00	5:00
Check layers, text, and dimensions	45:00	5:00
Adjust drawing objects to suit the CAD standard	30:00	5:00
Total time to complete task	80:00	15:00
<b>Time Savings with AutoCAD</b>		<b>81%</b>

(Figures shown in minutes and seconds)

## Advantages

- The CAD standards functionality in AutoCAD provides a highly efficient method of standards checking, with substantial time savings
- Checking CAD standards in AutoCAD LT is time-consuming with most of the checking requiring manual input, which can lead to errors and inaccuracies
- AutoCAD provides CAD standards functionality with the ability to save to the specific DWS file format to check against new and existing DWG files

## Design task 6

# Text editing (Express Tools)

The Express Tools are a set of utility tools available only in AutoCAD. Express Tools include text editing tools that could provide significant time savings. Most of the Express Tools are written by using the Application Programming Interface (API) in AutoCAD, therefore they do not work in AutoCAD LT as it does not have an API.

The task was to convert a group of drawing notes from single line text to multiline text, and then change the text from uppercase to mixed case. The text was then enclosed by an AutoCAD object (a rectangle) to highlight the text in the drawing.

### Steps:

- Convert single line text to multiline text
- Change the text from all uppercase to mixed case
- Enclose the text in an AutoCAD object (rectangle)

### NOTES:

1. ALL DIMENSIONS MUST BE IN
2. ALL CHANGES MUST BE REFER
3. ALL VARIATION ORDERS MUST

### Notes:

1. All dimensions must be
2. All changes must be ref
3. All variation orders mus

CAD standards	AutoCAD LT	AutoCAD
Convert text from single line to multiline	4:00	0:30
Change case from upper to mixed	2:30	0:30
Enclose text in an AutoCAD object (rectangle)	1:00	0:30
Total time to complete task	7:30	1:30
<b>Time Savings with AutoCAD</b>		<b>80%</b>

(Figures shown in minutes and seconds)

## Advantages

- The Express Tools in AutoCAD provide significant time savings over AutoCAD LT in the performing the tasks described
- The Express Tools could improve the efficiency of AutoCAD workflows when working with layers, text, and even blocks and viewports
- The Express Tools provide advanced workflows that will enhance productivity and efficiency when creating designs in AutoCAD

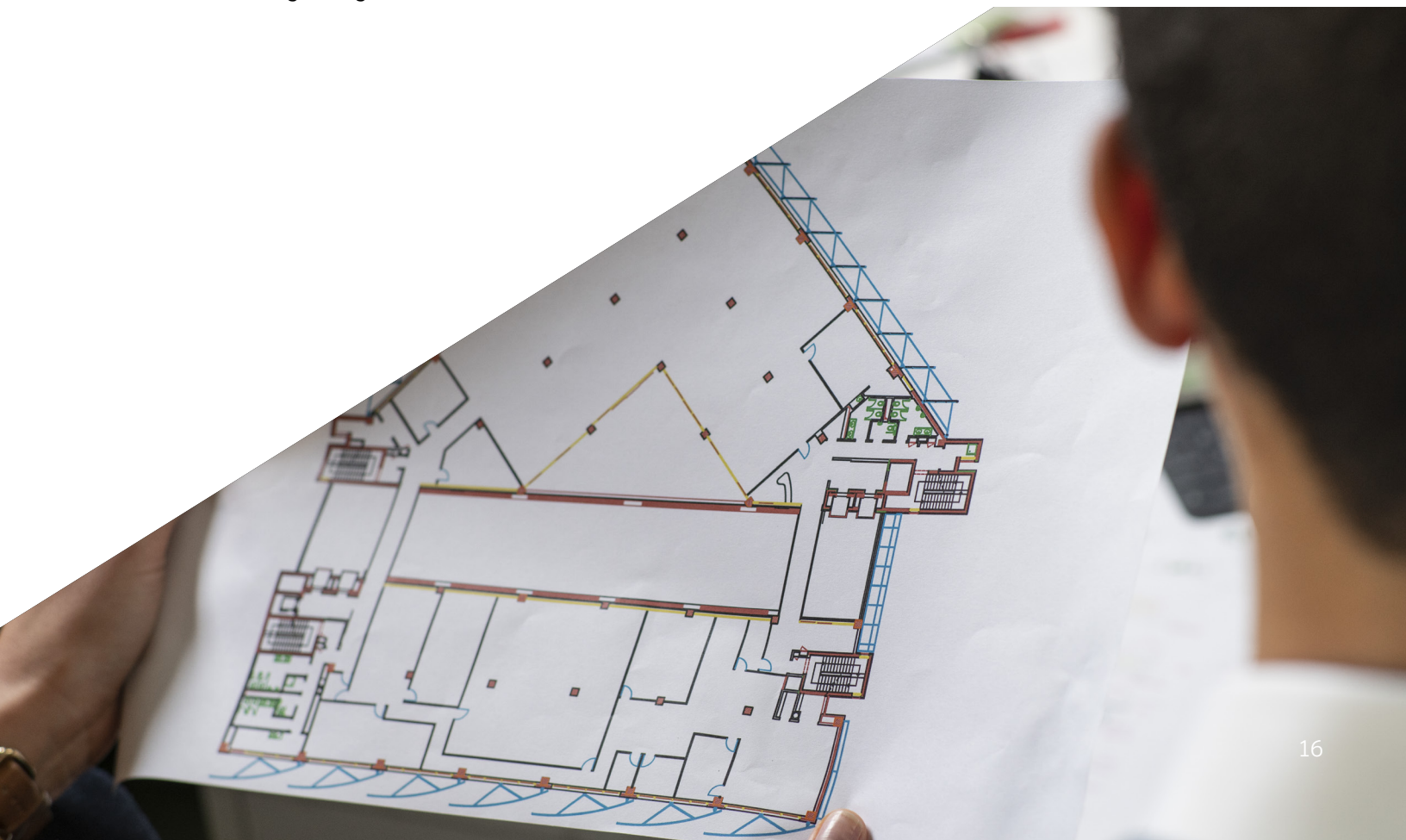



# Application programming interface (API) and the app store

There was no task related to this section, as the time savings vary depending on customer use and application requirements. AutoCAD offers an Application Programming Interface (API) which is not available in AutoCAD LT. This offers the following benefits that could provide significant time savings:

## Overview

- User programming to automate tedious, time-consuming tasks
- User programming to develop apps that will benefit AutoCAD users in your team
- The ability to use apps purchased or downloaded in the Autodesk App Store

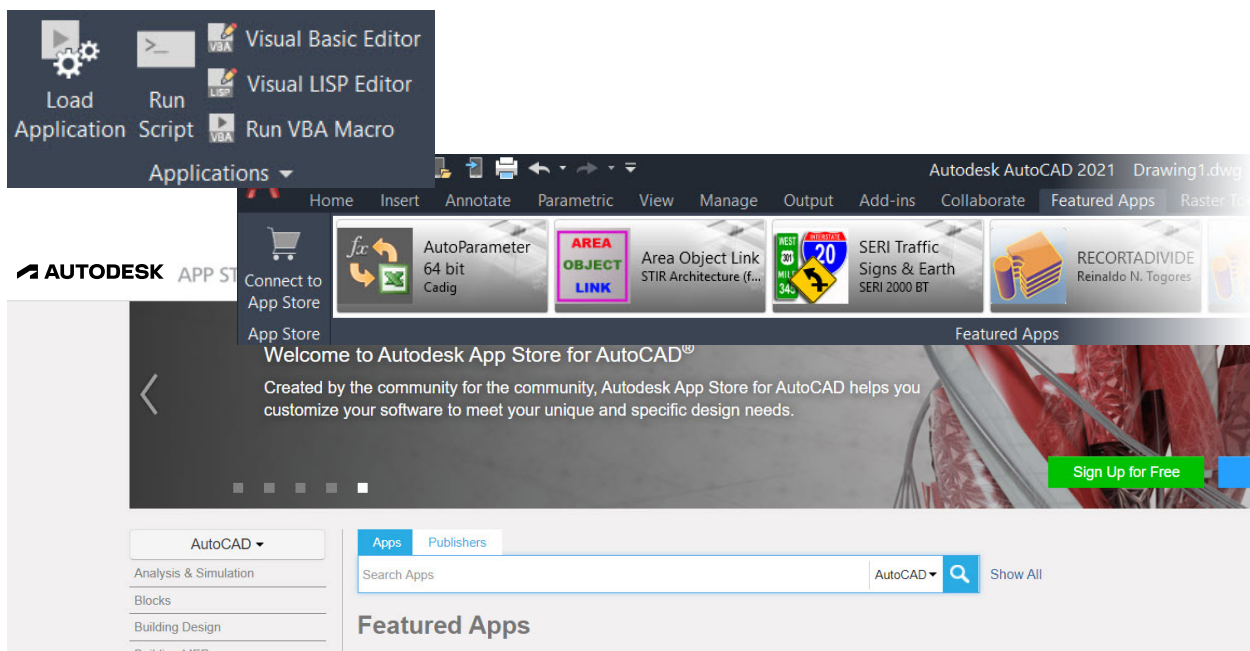

Application Programming Interface & App Store	AutoCAD LT	AutoCAD
Application Programming Interface (API)	NO	YES
Access to Autodesk App Store	NO	YES

(Figures shown in minutes and seconds)

## Advantages

- The API in AutoCAD provides tools for the user to develop their own routines and applications using Visual Basic or LISP. This will create the opportunity for users to automate tedious, time-consuming tasks that would take much longer if only using AutoCAD LT.
- In addition, access to the API in AutoCAD provides access to the Autodesk App Store where there is a multitude of apps available for purchase and download. The apps available may provide huge time savings for specific tasks in AutoCAD, thus enabling the AutoCAD user to be more efficient when working on their AutoCAD designs.



# Conclusion

In this AutoCAD LT vs. AutoCAD productivity study, the tasks analyzed were examples of how AutoCAD could provide tools and workflows to make you more productive.

Project tasks	AutoCAD LT	AutoCAD	Time Savings
1 Parametric constraints	10:30	7:00	33%
2 Plans and elevations	6:30	3:30	46%
3 Isometric drafting	14:00	5:30	61%
4 Data extraction	225:00	16:00	93%
5 CAD standards	80:00	15:00	81%
6 Text editing (Express Tools)	7:30	1:30	80%
<b>Total time</b>	<b>343:30</b>	<b>48:30</b>	
<b>Overall time savings with AutoCAD</b>			<b>86%</b>
<b>Overall productivity improvement with AutoCAD</b>			<b>7.1x</b>

(Figures shown in minutes and seconds)

Based on the six tasks listed in the table above, AutoCAD could provide a level of productivity for design creation that is not matched with AutoCAD LT. With AutoCAD, it was possible to generate an **overall time savings of up to 86%** when compared to AutoCAD LT.\* And, overall, AutoCAD could allow an AutoCAD designer to generate the designs up to **7.1 times quicker** as compared with AutoCAD LT.

\*As with all performance tests, results may vary based on machine, operating system, filters, and even source material. While every effort has been made to make the tests as fair and objective as possible, your results may differ. Product information and specifications are subject to change without notice. Autodesk provides this information “as is”, without warranty of any kind, either express or implied.

Autodesk is a registered trademark of Autodesk, Inc., and/or its subsidiaries and/or affiliates in the USA and/or other countries. All other brand names, product names, or trademarks belong to their respective holders. Autodesk reserves the right to alter product and services offerings, and specifications and pricing at any time without notice, and is not responsible for typographical or graphical errors that may appear in this document.

© 2022 Autodesk, Inc. All rights reserved.

